

On-board propellant management system for electric propulsion

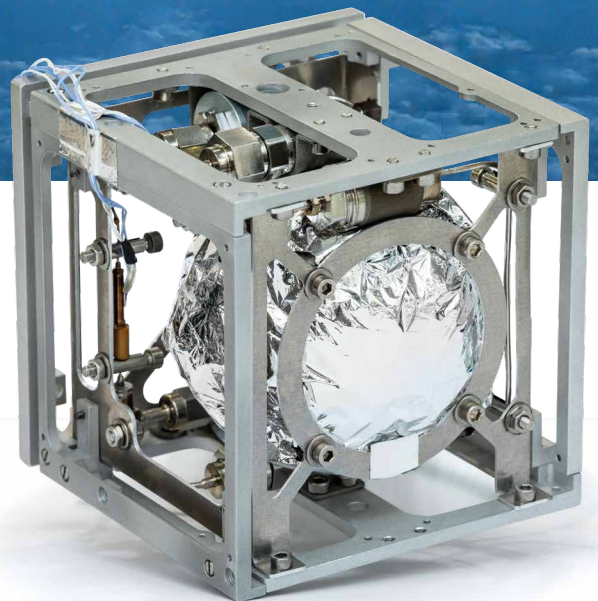

- ✓ Compact design
- ✓ Compliant with various propellants
- ✓ Cost efficiency
- ✓ High level of tightness
- ✓ Short lead time
- ✓ Low power consumption





Customized solutions for on-board electric propulsion management

Based on its cutting-edge technology *multi-function valve*, Air Liquide has developed a Flow Control Unit (FCU) and a Propellant Management Assembly (PMA) for a *wide range of satellites, such as cubesat, small and large satellites.*

Our solution and services

By leveraging Air Liquide's expertise in gas management and equipment manufacturing, our team offers customized solutions covering a wide range of components and systems for the management of propellants for electric propulsion.

Air Liquide masters the entire supply chain of the propellant, *from production (xenon, krypton) to delivery to the point-of-use*, and manufactures *filling equipment* (xenon loading cart). We offer *packaged solutions such as filling services* including gases needs.

Flow control unit

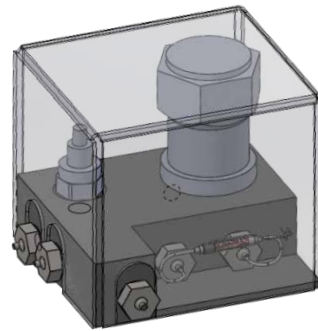

Propellant management assembly

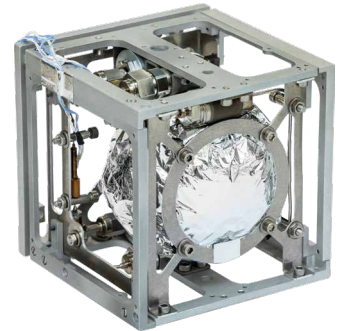

Our multi-function valve

Quantity of xenon to be loaded

Air Liquide's multi-function valve is a thermothrottle valve that features 2 functions:

- Flow rate regulation
- Pressure regulation



Technical characteristics

Maximum expected operating pressure	200 up to 300 bar
Fluid	Argon, krypton, xenon
Flow range	0.1-20 mg/s +/- 1 %
Internal / external leakage	10 ⁻⁷ mbar L/S GHe
Response time	20 s
Electrical consumption	3 W maximum
Weight	10 g

Contact us

gcom.alat@airliquide.com

www.advancedtech.airliquide.com

