

# OBIGGS for military cargo aircraft

## On-board inert gas generating system

A reliable and autonomous inerting system to protect the aircraft fuel tanks against any risk of fire or explosion

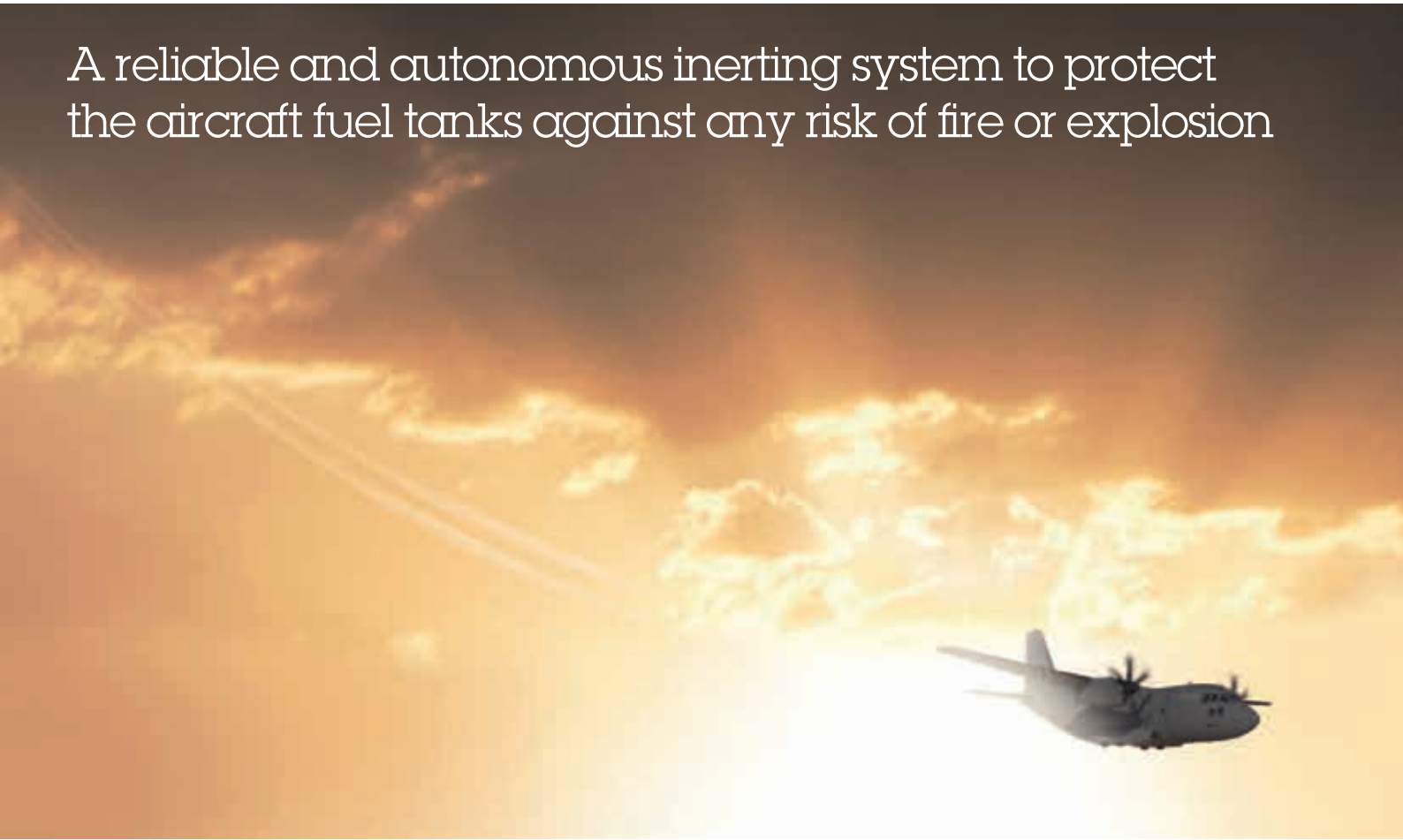

Due to its simple design the OBIGGS is a reliable equipment, generating nitrogen on board to fully protect the aircraft tanks against explosion. Based on a hollow fiber molecular separation process, the OBIGGS produces the flow of Nitrogen Enriched Air (NEA), keeping the ullage non-flammable.

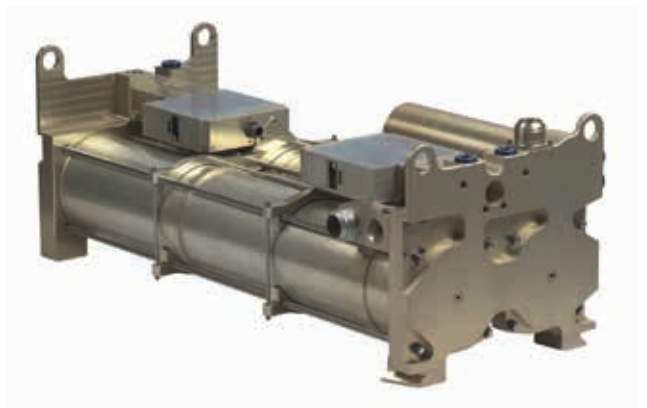

# Why should you select an OBIGGS?

---

- ✓ To protect the helicopter fuel tanks against explosion and increase its survivability
- ✓ To improve crew members safety
- ✓ To avoid ground and logistics supports
- ✓ To choose a light and reliable inerting system

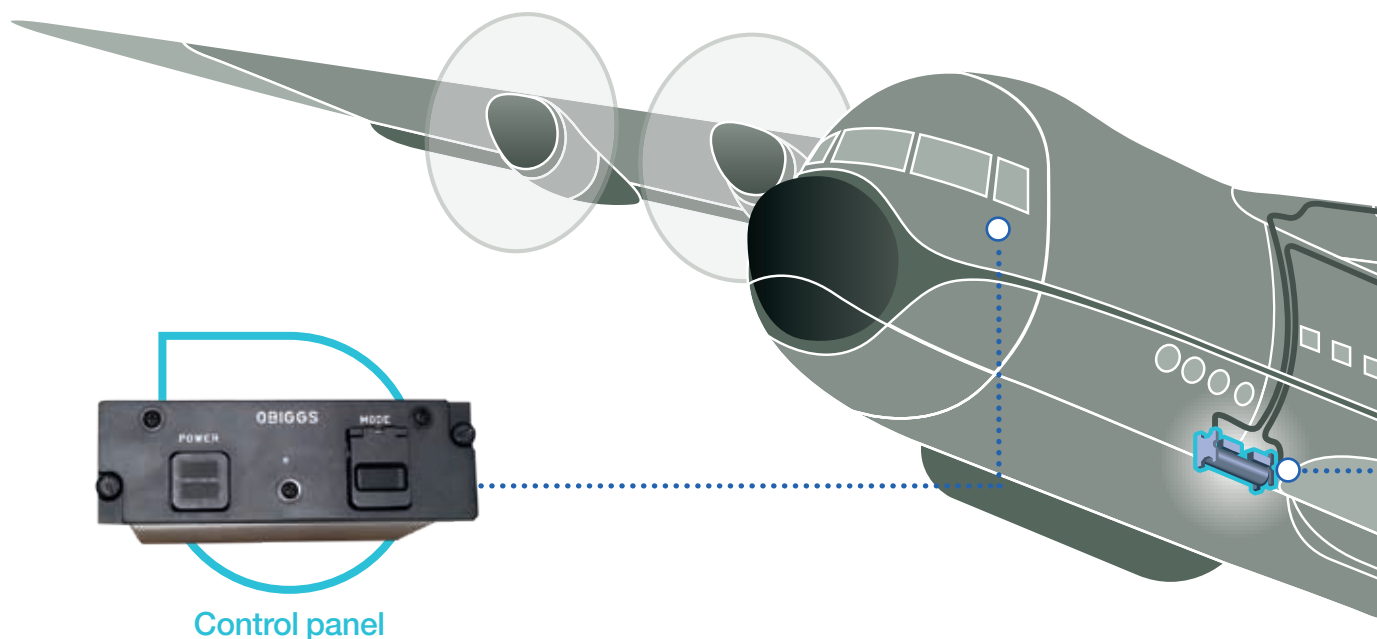

## The pros of its technology and design

---

- Fast and accurate regulation of the gas
- Flexible and simple integration
- Compact lightweight system
- No calibration nor logistic
- Control signals to monitor the operational status of the equipment
- Reduced schedule maintenance
- Integrated controller
- Temperature Management System allowing to use bleed air with temperatures up to 400°C

## The pros of Air Liquide expertise

---

Our expertise in the fields of gases separation, analysis and storage allows to offer a global solution adaptable to your needs, integrating:

- Definition of specifications
- Gas distribution design (inerting modelling, piping sizing...)
- Supply of distribution components (hollow fibers membrane...)
- Manufacturing
- Integration
- Full support

# Why should you select an Air Liquide's OBIGGS?

The Air Liquide's OBIGGS has several pros coming from its up to date technology and the world wide recognized gas expertise of the Group.

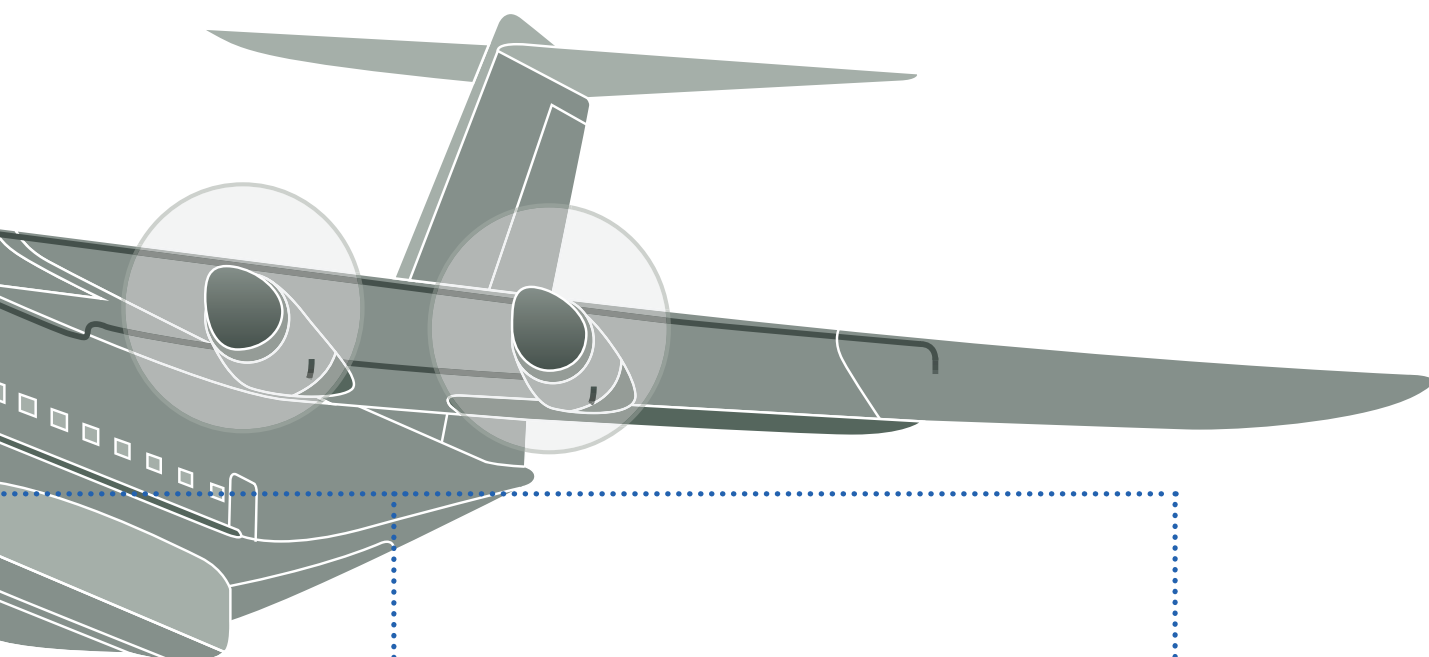

Analyser

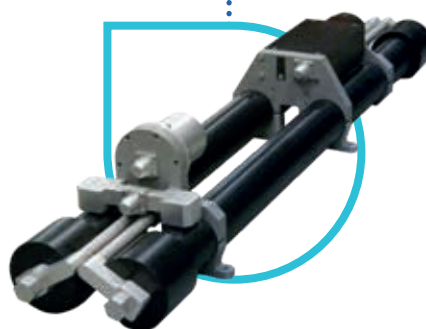

OBIGGS  
On-board gas generating system

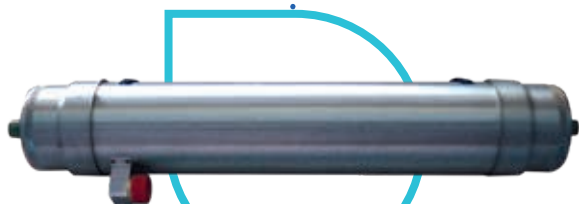

Membrane



## Main technical characteristics

	Cargo aircraft	Training aircraft
Weight	< 35 kg	< 10 kg
Flow	Up to 2 lb/min	Up to 0.2 lb/min
NEA (Nitrogen Enriched Air)	Up to 1% O <sub>2</sub>	Up to 4% O <sub>2</sub>
Power supply	28 Vdc	28 Vdc

Separation by MEDAL hollow fibers membrane.

## References

- Alenia C27J military cargo aircraft
- CASA-EADS C295 military cargo aircraft

## Contacts

**Air Liquide**  
Advanced Technologies

2, rue de Clémencière  
BP 15 – 38360 Sassenage, France  
Phone: +33 4 76 43 66 46  
E-mail: [gcom.alat@airliquide.com](mailto:gcom.alat@airliquide.com)  
[www.advancedtech.airliquide.com](http://www.advancedtech.airliquide.com)

[www.airliquide.com](http://www.airliquide.com)



A world leader in gases, technologies and services for Industry and Health, Air Liquide is present in 73 countries with approximately 67,100 employees and serves more than 3.9 million customers and patients.